

ODIN MIT4 02

Fiber Optic Transmitter for MOST®

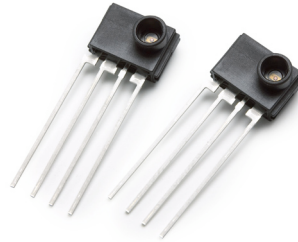

Data Sheet



Description

The 4-pin MOST Optical Transmitter (ODIN MIT4 02) is a highly integrated CMOS IC combined with a high speed LED designed to transmit up to 25 Mbit/s optical data which is biphase coded (up to 50 Mbaud). The internal peaking circuit minimizes PWD. The current through the LED will be setup by an external resistor connected to VCC. This makes it possible to control the optical output power of the LED. The power supply voltage is either 3.3V or 5.0V. The power down mode switches the part into a low power mode if electrical data is not received.

Applications

- Optical Transmitter for MOST Systems

Features

Excellent solution for converting high speed data from TTL to Plastic Optical Fiber (POF)

- Operating @ 3.3V or 5V Power Supply
- High speed transmitter up to 25 Mbit/s net data rate (50 MBaud)
- 95°C operating temperature over whole life time
- TTL Data Input (Logic to Light Function)
- Power down mode
- Duty Cycle Adjust (DCA), yields to enhanced SP1 input range
- 650 nm for working in a low attenuation range of PMMA Fiber
- High coupled power in 1000 micron plastic fiber
- Fully compliant to "MOST® Specification of Physical Layer Rev 1.1"
- RoHS compliant (Lead free and halogen free)

Safety Hints

Applications of new chip technologies lead to increasing optical efficiency and growing and higher levels of optical performance. We therefore recommend that the current versions of the IEC 60825-1 and EN 60825-1 standards are taken into account right from the outset, i.e. at the equipment development stage, and that suitable protection facilities are provided.

Table 1. Absolute Maximum Ratings

Parameter	Symbol	Limit Values		
		min.	max	Unit.
Supply Voltage	V_{CCMax}	-0.5	6.0	V
Storage Temperature Range	T_{STG}	-40	100	°C
Soldering Temperature (>2.5 mm from case bottom $t \leq 10s$)	T_S	–	260	°C
Voltage at any PIN		-0.5	$V_{CC} + 0.5$	V
Electrostatic Discharge Voltage Capability ^[1]	ESD	–	2.0	kV

Notes:

- ESD Capability for all Pins HBM (human body model) according JESD22-A114B.

Table 2. Recommended Operating Conditions

Parameter	Symbol	Limit Values		
		min.	max.	Unit
Supply Voltage low	V_{CC_l}	3.135	3.465	V
Supply Voltage high	V_{CC_h}	4.75	5.25	V
Operating Temperature Range (ambient) ^[1]	T_A	-40	95	°C

Notes:

- For details see application note “Handling, Storage, Operating and Processing Application Note of ODIN MOST4 Transceiver”

All the data in this specification refers to the operating conditions above and over life time unless otherwise stated.

Table 3. DC Characteristics

Parameter	Symbol	Limit Values			Unit
		min.	typ.	max.	
Low Level Input Voltage	V_{IL}	-0.3	–	0.8	V
High Level Input Voltage	V_{IH}	2.0	–	$V_{CC} + 0.3$	V
Input Leakage Current($V_{CC} = 5.0 V$, $V_I = 0.0 V$ or $V_I = 5.0 V$)	I_L	–	–	± 20	μA
Input Capacitance	C_I	–	–	7	pF
Input Resistance	R_I	2	–	–	k Ω
Supply Current ($R_{ext} = 15 k\Omega$) ON state, biphase coded data ^[1]	I_{CC}	–	-35	mA	
Supply Current ($R_{ext} = 15 k\Omega$) OFF state ^[2]	I_{LP2}	–	–	20	μA

Notes:

- The current through the LED and therefore the optical output power and overall power consumption depends on the settings of R_{ext} . The nominal value for R_{ext} is 15 k Ω . With $R_{ext} = 30 k\Omega$ the optical output power is about -3 dB of the nominal value. Typical behavior see Figure 1. **Important: The external resistor of R_{ext} must be within the range of 13.5 k Ω to 33 k Ω . For values of R_{ext} out of this range functionality may not be given over the whole temperature range and the device lifetime. Using values below 13 k Ω for R_{ext} can damage the transmitter.**
- If the transmitter is in full power mode it is switched OFF 1 ms (max.) after TX DATA is low. If the transmitter is in low power mode it is switched ON 6 ms (max.) after TX DATA transmission starts.

Attention

Stresses above those listed here may cause permanent damage to the device. Exposure to absolute maximum rating conditions for extended periods may affect device reliability. Between 3.465V and 4.75V the device is not specified according Table2. Therefore operation is limited to the range of 3.135V ... 3.465V or 4.75V ... 5.25V.

Table 4. AC Electrical Characteristics

Parameter	Symbol	Limit Values			Unit	Test Conditions
		min.	typ.	max.		
Power Up Time	T _{PU}	–	0.016	6	ms	Zero -->MOST
DataPower Down Time	T _{PD}	–	0.01	1.0	ms	MOST Data -->Zero

Optical Signal Characteristics(22.5 Mbit MOST Data, V_{CC} = 3.135 ... 3.465 V or 4.75 ... 5.25 V, R_{ext} = 15 kOhm)

Parameter	Symbol	Limit Values			Unit
		min.	typ.	max.	
Peak wavelength	λ_{Peak}	630	650	685	nm
Temperature coefficient λ_{Peak}	TC _{λ}	–	0.16	–	nm/K
Spectral bandwidth (FWHM)	Delta _{λ}	–	20	30	nm
Average Output Power coupled into plastic fiber [1]	P _{opt}	-9.0	-5.2	-2.0	dBm
Average Output Power coupled into plastic fiber (if R _{ext} = 13.5k is used instead of R _{ext} = 15k)[1]	P _{opt}	-8.5	-4.7	-1.5	dBm
Optical Output Power "Light off"[2]	P _{off}	–	–	-50	dBm
Optical Rise Time (20% - 80%)[4]	t _r	–	2.5	6	ns
Optical Fall Time (20% - 80%)[4]	t _f	–	3.5	6	ns
Extinction Ratio[4][6]	r _e	10	12	–	dB
Pulse Width Variation [3][4][5]	t _{pWV}	20.0	–	24.3	ns
Average Pulse Width Distortion[3][4]	t _{APWD}	-1.4	–	1.4	ns
Data Dependent Link Jitter[3][4]	t _{DDJ}	–	0.2	0.77	ns
Uncorrelated Link Jitter[3][4]	t _{UJ}	–	0.05	0.33	ns
Positive Overshoot within 0UI..2/3UI[4][6]		-20	–	40	%
Negative Overshoot within -1UI..-1/4UI[4][6]		-10	–	20	%
High Level Signal Ripple between 2/3UI and 3/4UI[4][6]		-10	–	10	%

Notes:

1. Average value, when transmitting modulated light @ signal timing paramters. The output power coupled into plastic fiber P_{opt} is measured with a large area detector at the end of 30 cm POF fiber with a NA = 0.5, which is ideally coupled to the transmitter.
2. Average value, when signal on Tx_Data is low.
3. The electrical input signal has to fulfill following requirements: t_{pWV(min)} = 20.1 ns, t_{pWV(max)} = 24.1 ns, t_{APWD(min)} = -1.5 ns and t_{APWD(max)} = 1.5 ns, t_{DDJ(max)} = 0.22 ns, t_{UJ(max)} = 0.10 ns.
4. Characterized with Infineon Characterization Boards as described in the Application note "Application Note MOST circuit for Infineon ODIN Transceiver"
5. Limits for 2UI are 42.2 ... 46.4ns and for 3UI they are 64.3 ... 68.5ns
6. Top and Base level measured at least over 10UIs

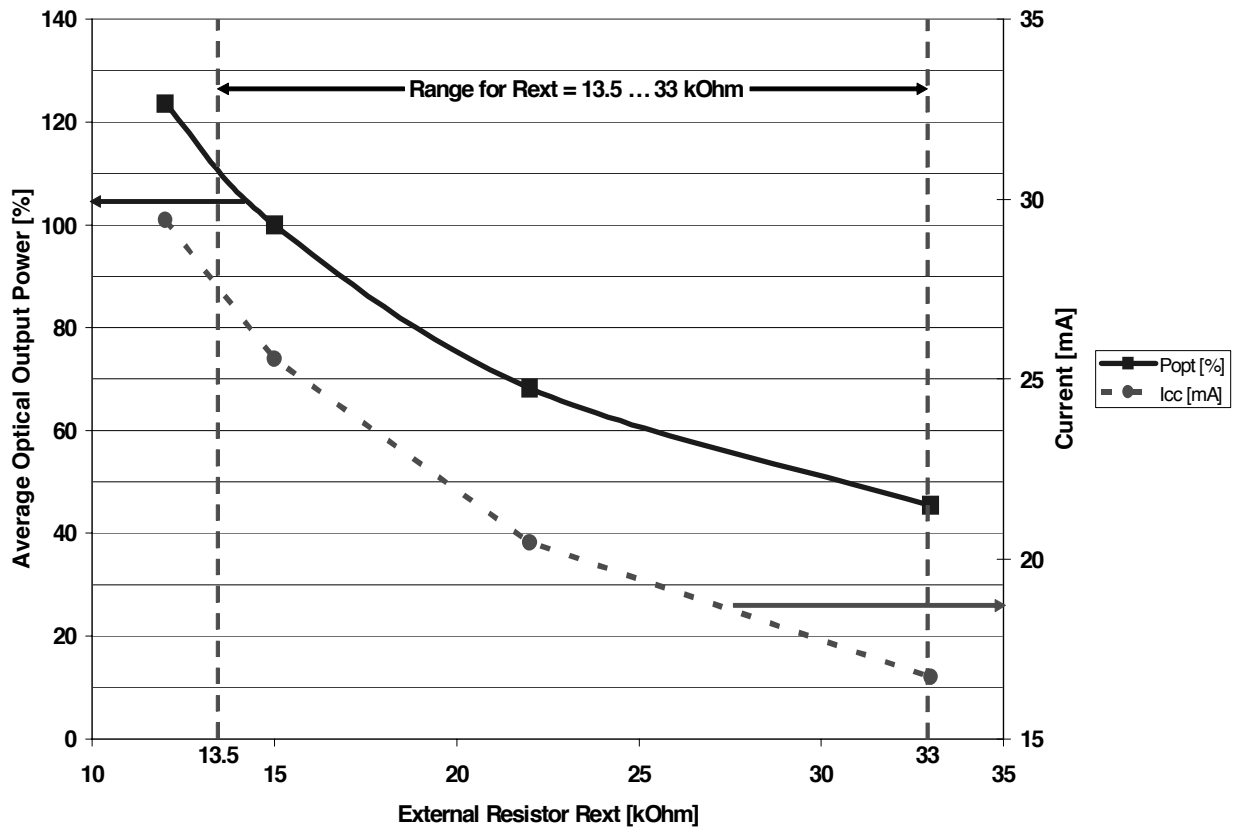
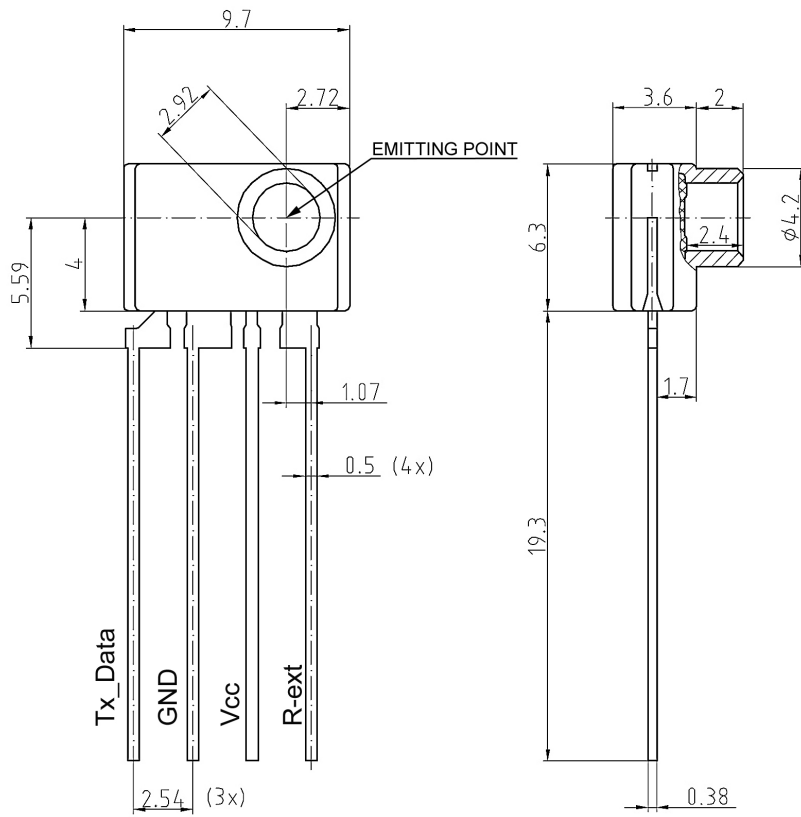

Figure 1. Typical Dependency of Average Optical Output Power P_{opt} and Supply Current versus External Resistor R_{ext} (22.5 Mbit MOST Data, $V_{CC} = 5.0\text{ V}$, $T_A = 25^\circ\text{C}$)

Package Outlines

ODIN MIT4 02(Cavity as Interface Package)



Dimensions in mm

For a more detailed drawing please contact Avago Technologies.

Disclaimer

The information herein is given to describe certain components and shall not be considered as a guarantee of characteristics.

Terms of delivery and rights to technical change reserved. We hereby disclaim any and all warranties, including but not limited to warranties of non-infringement, regarding circuits, descriptions and charts stated herein.

Warnings

Due to technical requirements components may contain dangerous substances. For information on the types in question please contact your nearest Avago Technologies Office.

Avago Technologies Components may only be used in life-support devices or systems with the express written approval of Avago Technologies, if a failure of such components can reasonably be expected to cause the failure of that life-support device or system, or to affect the safety or effectiveness of that device or system. Life support devices or systems are intended to be implanted in the human body, or to support and/or maintain and sustain and/or protect human life. If they fail, it is reasonable to assume that the health of the user or other persons maybe endangered.

Information

For further information on technology, delivery terms and conditions and prices please contact your nearest Avago Technologies Office (www.avagotech.com).

For product information and a complete list of distributors, please go to our web site: www.avagotech.com

Avago, Avago Technologies, and the A logo are trademarks of Avago Technologies, Limited in the United States and other countries.
Data subject to change. Copyright © 2007 Avago Technologies Limited. All rights reserved.
AV01-0722EN - July 1, 2007

Avago
TECHNOLOGIES