

ODIN MIR4 02

Fiber Optic Receiver for MOST®

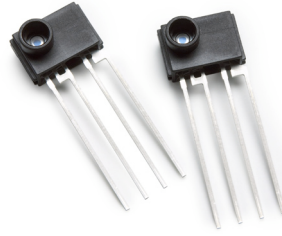

Data Sheet



Description

The 4-pin MOST Optical Receiver (ODIN MIR4 02) is a highly integrated CMOS IC combined with a high speed PIN diode designed to receive up to 25 Mbit/s optical data which is biphase coded (up to 50 Mbaud) and convert this optical data to a rail-to-rail data stream. During the low power mode, the PIN diode is still being observed and if activity is detected, the receiver will switch to full power mode. A STATUS-pin indicates if modulated light is received (Light on -> STATUS = low). With the STATUS-pin the power supply of the whole MOST device can be switched ON. The power supply voltage is either 3.3V or 5V.

Applications

- Optical Receiver for MOST Systems

Features

Excellent solution for converting high speed data from Plastic Optical Fiber (POF) to digital output.

- Operating @ 3.3V or 5V Power Supply
- High speed receiver up to 25 Mbit/s net data rate (50 MBaud)
- 95°C operating temperature over whole life time
- Photo current sensing, network activity detection and Low Power Mode ($I_{CC} < 10 \mu A$)
- Signal detect and Status Output
- Low power consumption
- Pulse width control
- -25dBm guaranteed sensitivity @ 650nm for working in a low attenuation range of PMMA Fiber
- Fully compliant to "MOST® Specification of Physical Layer Rev 1.1"
- RoHS compliant (Lead free and halogen free)

Table 1. Absolute Maximum Ratings

Parameter	Symbol	Limit Values		
		min.	max.	Unit
Supply Voltage ^[1]	V _{CCMax}	-0.5	6.0	V
Storage Temperature Range	T _{STG}	-40	100	°C
Soldering Temperature (>2.5 mm from case bottom t ≤ 10s)	T _S	–	260	°C
Voltage at any PIN		-0.5	V _{CC} +0.5	V
Electrostatic Discharge Voltage Capability ^[2]	ESD	–	2.0	kV

Notes:

1. Maximum supply voltage without causing damage
2. ESD Capability for all Pins HBM (human body model) according JESD22-A114B.

Table 2. Recommended Operating Conditions

Parameter	Symbol	Limit Values		
		min.	max.	Unit
Supply Voltage low	V _{CC_l}	3.135	3.465	V
Supply Voltage high	V _{CC_h}	4.75	5.25	V
Operating Temperature Range (ambient) ^[1]	T _A	-40	95	°C

Notes:

1. For details see application note “Handling, Storage, Operating and Processing Application Note of ODIN MOST4 Transceiver”

All the data in this specification refers to the operating conditions above and over life time unless otherwise stated.

Table 3. Optical Signal Characteristics(22.5 Mbit MOST Data, V_{CC} = 3.135 ... 3.465 V or 4.75 ... 5.25 V)

Parameter	Symbol	Limit Values			Unit
		min.	typ.	max.	
Peak wavelength of input signal	λ _{Peak}	630	650	685	nm
FWHM of input signal	Δλ	–	–	30	
Receivable optical power range for data recovery ^{[1][2]}	P _{opt}	-25	–	-2	dBm
Receivable optical power for switching to low power mode ^[1]	P _{OFF}	-40	–	-25	dBm

Notes:

1. Optical power data are average values when using a MxT4 xx optical transmitter, measured at the end of a plastic optical fiber with metal insert (diameter 2.90 +/- 0.02 mm). The transmitted data is biphase coded.
2. Measured with worst case pattern. A BER ≤ 10⁻⁹ can be reached.

Attention

Stresses above those listed here may cause permanent damage to the device. Exposure to absolute maximum rating conditions for extended periods may affect device reliability. Between 3.465V and 4.75V the device is not specified according Table 2. Therefore operation is limited to the range of 3.135V ... 3.465V or 4.75V ... 5.25V.

Table 4. AC Electrical Characteristics

Parameter	Symbol	Limit	Values		Unit
		min.	typ.	max.	
Output Rise Time ^{[1][4]}	t_r	–	6	9	ns
Output Fall Time ^{[1][4]}	t_f	–	6	9	ns
Output Pulse Width Variation 1UI ^{[1][2][3][4][5]}	t_{PWV}	16.5	–	31.0	ns
Output Average Pulse Width Distortion ^{[1][2][3][4]}	t_{APWD}	-3.3	–	7.0	ns
Data Dependent Link Jitter ^{[2][3][4]}	t_{DDJ}	–	–	3.3	ns
Uncorrelated Link Jitter ^{[2][3][4]}	t_{UJ}	–	–	1.0	ns
Power-up time at detection of rising V_{CC}	t_{PU0}	–	0.1	6	ms
Power-up time from low power mode	t_{PU}	–	0.5	6	ms
Low Power mode timer delay	t_{LPM}	–	0.005	2	ms

Notes:

- Capacitive Load is max. 10pF
- MOST Data 44.1 kHz FS corresponds to a 45 MBaud data stream.
- The optical input signal has to fulfill following requirements: $t_{PWV(\min)} = 20.0$ ns, $t_{PWV(\max)} = 24.3$ ns, $t_{APWD(\min)} = -1.4$ ns and $t_{APWD(\max)} = 1.4$ ns, $t_{DDJ(\max)} = 0.77$ ns, $t_{UJ(\max)} = 0.33$ ns, Positive Overshoot within 0UI...2/3UI = -20...40%, Extinction Ratio min = 10dB. Variation within those limits does not significantly change t_{PWV}
- Characterized with Infineon Characterization Boards as described in the Application note "Application Note MOST circuit for Infineon ODIN Transceiver"
- Limits for 2UI are 38.6 ... 53.1ns and for 3UI they are 60.8 ... 75.2ns

Table 5. DC Electrical Characteristics

Parameter	Symbol	Limit	Values		Unit
		min.	typ.	max.	
Supply Voltage low	V_{CC_l}	3.135	3.3	3.465	V
Supply Voltage high	V_{CC_h}	4.75	5	5.25	V
Low Level Output Voltage Data and Status Pin ^[1]	V_{OL}	–	–	0.4	V
High Level Output Voltage Data Pin ^[1]	V_{OH}	2.5	3.3	3.7	V
High Level Output Voltage Status Pin ^[1]	V_{OH}	2.5	– ^[1]	V_{CC}	V
Supply Current Full Power Mode	$I_{CC,FPM}$	–	–	15	mA
Supply Current LowPower Mode	$I_{CC,LPM}$	–	–	10	μ A

Notes:

- Resistor load must not be smaller than 50kOhm

Package Outlines

(Cavity as Interface Package)

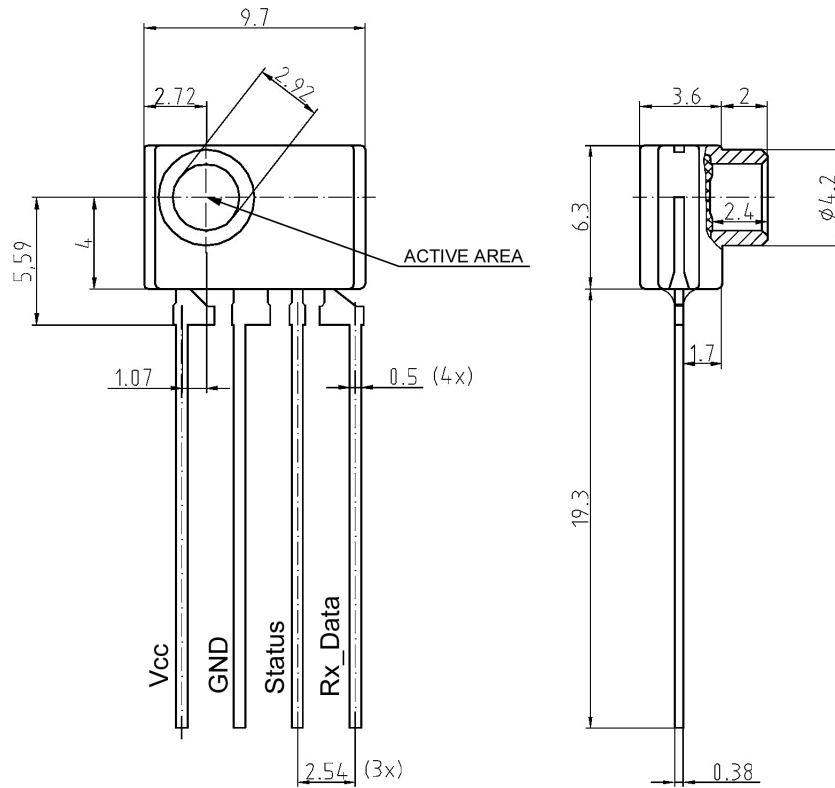

Dimensions in mm

For a more detailed drawing please contact Avago Technologies.

Disclaimer

The information herein is given to describe certain components and shall not be considered as a guarantee of characteristics.

Terms of delivery and rights to technical change reserved. We hereby disclaim any and all warranties, including but not limited to warranties of non-infringement, regarding circuits, descriptions and charts stated herein.

Warnings

Due to technical requirements components may contain dangerous substances. For information on the types in question please contact your nearest Avago Technologies Office.

Avago Technologies Components may only be used in life-support devices or systems with the express written approval of Avago Technologies, if a failure of such components can reasonably be expected to cause the failure of that life-support device or system, or to affect the safety or effectiveness of that device or system. Life support devices or systems are intended to be implanted in the human body, or to support and/or maintain and sustain and/or protect human life. If they fail, it is reasonable to assume that the health of the user or other persons maybe endangered.

Information

For further information on technology, delivery terms and conditions and prices please contact your nearest Avago Technologies Office (www.avagotech.com).

For product information and a complete list of distributors, please go to our web site: www.avagotech.com

Avago, Avago Technologies, and the A logo are trademarks of Avago Technologies, Limited in the United States and other countries.
Data subject to change. Copyright © 2007 Avago Technologies Limited. All rights reserved.
AV01-0721EN - July 1, 2007

Avago
TECHNOLOGIES