Broadband Home Network in Korea

Chang-Won Park
Optimedia, Inc.
Seongnam-Si, Korea

May, 2006



TOPICS

- **IT 8-3-9 strategy**
(Ministry of Information and Communication, MIC)
 - **Broadband Home Network**
 - **Implementation of FTTH in Korea**
- Guidelines on Broadband Certified Buildings
 - **Labor Standards for Optical Cable Installation**
 - **POF for multi-dwelling unit builds**
-

IT 8-3-9 Strategy

Plan for Broadband IT Korea introduced in May 2004 by the Ministry of Information and Communication (MIC)

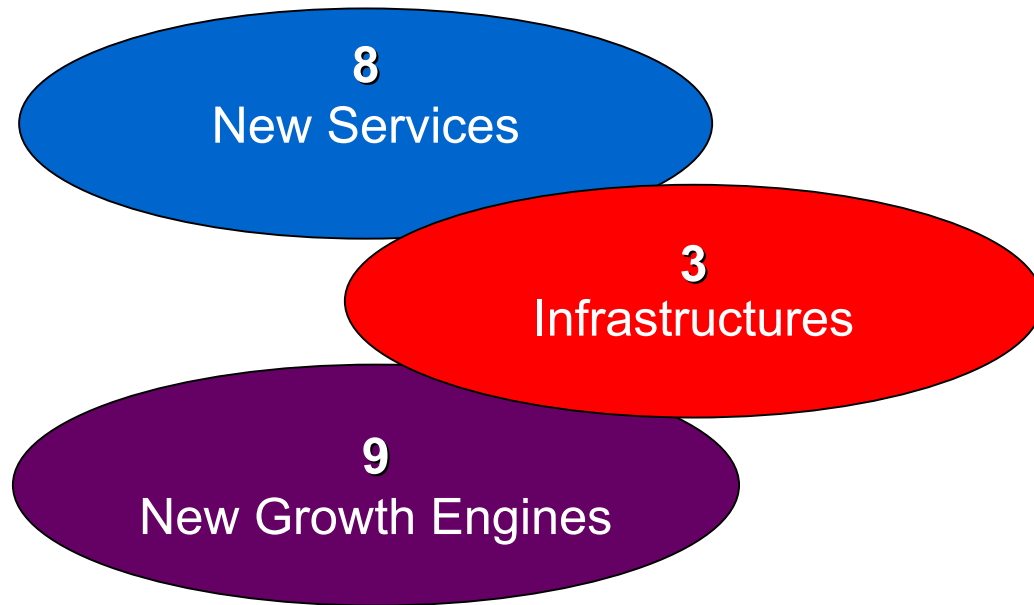

8 New Services

1. WiBro service (wireless broadband)
 2. DMB service (Digital Multimedia Broadcasting)
 - 3. Home network service**
 4. Telematics service
 5. RFID based service
 6. W-CDMA service (Wideband CDMA)
 7. Terrestrial Digital TV
 8. Internet Telephony (VoIP)
-

3 Infrastructures

1. Broadband Convergence Network (BcN)

- *Broadband network for TPS (Triple Play Service).*
- *Convergence of voice, broadcasting and the Internet (data).*
- *FTTH based Subscriber Access Network.*

2. Ubiquitous-Sensor Network (USN)

- *Information management over the Internet through RFID tag*
- *U-Life by 2010*

3. Next-generation Internet Protocol (IPv6)

- *Promote IPv6 implementing the BcN.*
 - *All-IP based services by 2010*
-

Broadband Convergence Network (BcN)

- **BcN by 2010**

- *50~100Mbps to 20 million fixed and wireless subscribers*
- *Quality of Service (QoS), Security and IPv6*
- ***Broadband optical home network for broadcasting***
- *Revise relevant laws and regulations*

- **4 Layers of BcN**

- *Service and control layer*
 - *BcN core network layer*
 - *Subscriber network layer*
 - ***Home and terminals layer***
-

Broadband Home Network

- **Convenient life:**

- *Interactive Cyber Education*
- *Telemedicine*
- *Video-conferencing*
- *Home automation*

- **Safe life:**

- *Home security*
Remote video surveillance
Valve control (gas, water, etc.)
- *Personal info management*

**Home
Network**

- **Happy life:**

- *Interactive DTV*
- *Multimedia service*
- *Network game service*

- **Pleasant life:**

- *Home banking*
- *Interactive Home Shopping*
- *On-line information service*

- 2 million homes in 2005 / 10 million homes by 2007 (60% of total)
- Telecom-Broadcasting convergent home server in 2005 /
Telecom-Broadcasting-Game convergent home server in 2007
- *Guidelines on broadband certified building*

Bandwidth requirement for home network

Services	Bandwidth (Mbps)	Terminals
Internet	10	PC
VoD	20	TV / PC
Web surfing	5	PC
Game	2	PC
Video conference	20	PC /TV
Broadcasting (CATV / Sat.TV)		
HDTV / ch	20	TV
SDTV / ch	5	TV
ATV / ch	4	TV
IP broadcasting / ch	20	PC / TV
Telemetry, Home appliance control	1	PC / mobile

Broadband Home Network

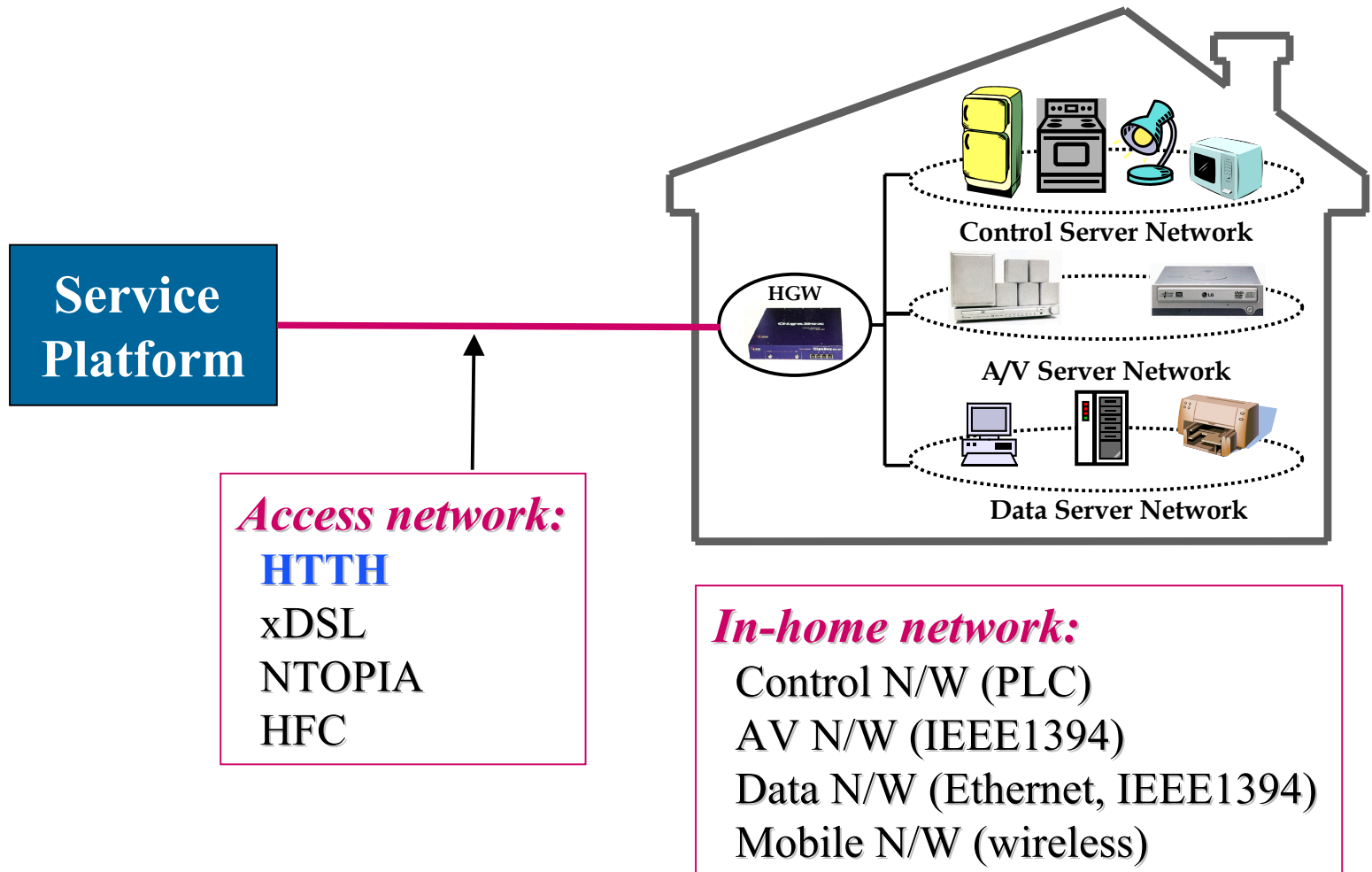

Definition of FTTH

Optical based access network

Fiber to the home terminal box or home outlet

Broadband (50 ~ 100 Mbps) / QoS / Triple Play Service

- **Progress of FTTH in Korea**

- 100 % of FTTB (MDF) for Business Building*

- 90 % of FTTB (MDF) for Multi-dwelling unit building (April 2005)*

- 70 % of FTTH (BBX) for Residential Home (Dec. 2005)*

- **Subscriber Access Network for FTTH**

- AON (Active Optical Network),*

- PON (Passive Optical Network)*

- A(ATM)-, B(Broadband)-, E(Ethernet)-, G(Gigabit)-, WDM-PON*

AON vs. PON

	Pros	Cons
AON	<p>Commercialized technology</p> <p>Unlimited bandwidth/ High security</p>	<p>High management and operation cost</p> <p>Increase with user BW</p>
A-PON B-PON	<p>Mature technology</p> <p>Multi-service QoS</p>	<p>Relatively higher cost in installation and operation</p> <p>Does not provide enough BW</p> <p>Security issues for broadcasted down stream data</p>
E-PON	<p>Lower-Cost of BW</p> <p>Optimized for scalable data network interface</p>	<p>Many E-QoS issues for real time traffic to be resolved</p> <p>Does not provide enough BW</p> <p>Security issues for broadcasted down stream data</p>
G-PON	<p>BW efficiency over 90%</p> <p>Transparency toward ATM and TDM edge</p>	<p>Immature technology and expensive chipset</p> <p>Security issues for broadcasted down-stream data</p>
WDM-PON	<p>High security / Unlimited BW</p> <p>High link budget</p> <p>Protocol transparency</p>	<p>Wavelength specified source</p> <p>High cost of light source</p> <p>High cost of Mux / Demux</p>

Implementation of HTTH

- ***Guidelines on Broadband Certified Building***

- *Started in April, 1999*
- *FTTH guidelines on condominium/apartment in Jan. 2004*
- *3,395 new buildings /1,500,000 households (Feb. 2005)*



Implementation of HTTH

- *Guidelines on Broadband Certified Building*

Class	Apartment house entrance cables per home	Office building distribution cables per 10.
Platinum	Optical fiber / 4 cores Cat.3 / 4 pairs	-
1st class	Cat.5e / 4 pairs x 2	Optical fiber / 2 cores Cat.5e / 4 pairs x 2
2nd class	Cat.5e / 4 pairs	Cat.5e / 4 pairs x 2
3rd class	Cat.3 / 4 pairs	Cat.3 / 4 pairs

4 cores of optical fiber / home (including POF)

Implementation of HTTH

- *Multi-dwelling unit building (platinum level)*

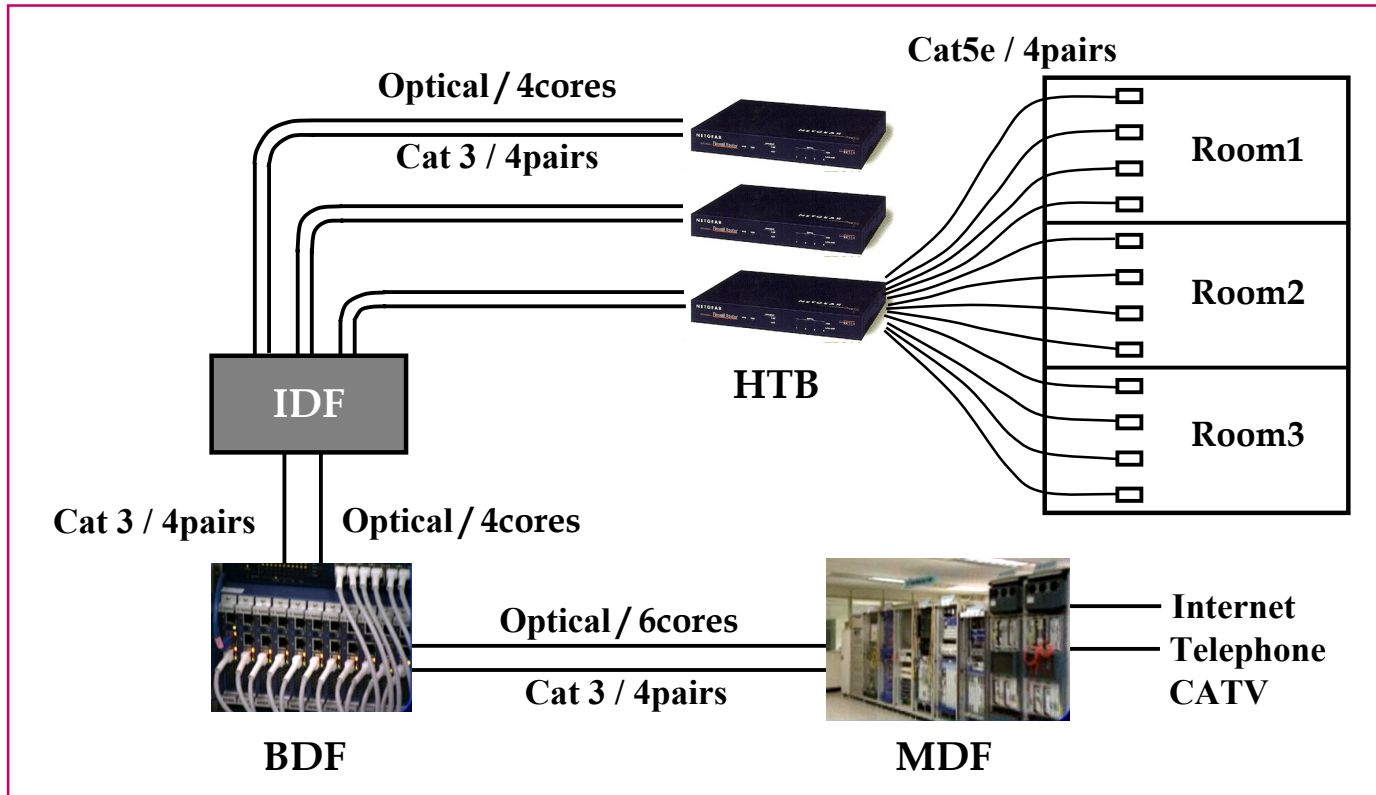

MDF: Main Distribution Frame of building Complex **BDF:** Building Distribution Frame
IDF: Intermediate Distribution Frame **HTB:** Home Terminal Box

Implementation of FTTH

- *Revision of Guidelines*

- **FTTH for old buildings:**

- Multi-unit home building (> 50 households)*

- FTTH for platinum class / FTTC for 1st-2nd class*

Residential buildings in Korea:

Single-unit house	Multi-unit house			Residential home in business building	Total
	Apartment	Condominium	Subtotal		
4,069,463	5,231,319	1,265,989	6,497,308	392,571	10,959,342
37%	48%	11%	59%	4%	100%

National Statistical Office, 2000

Implementation of HTTH

- **FTTH for old buildings**

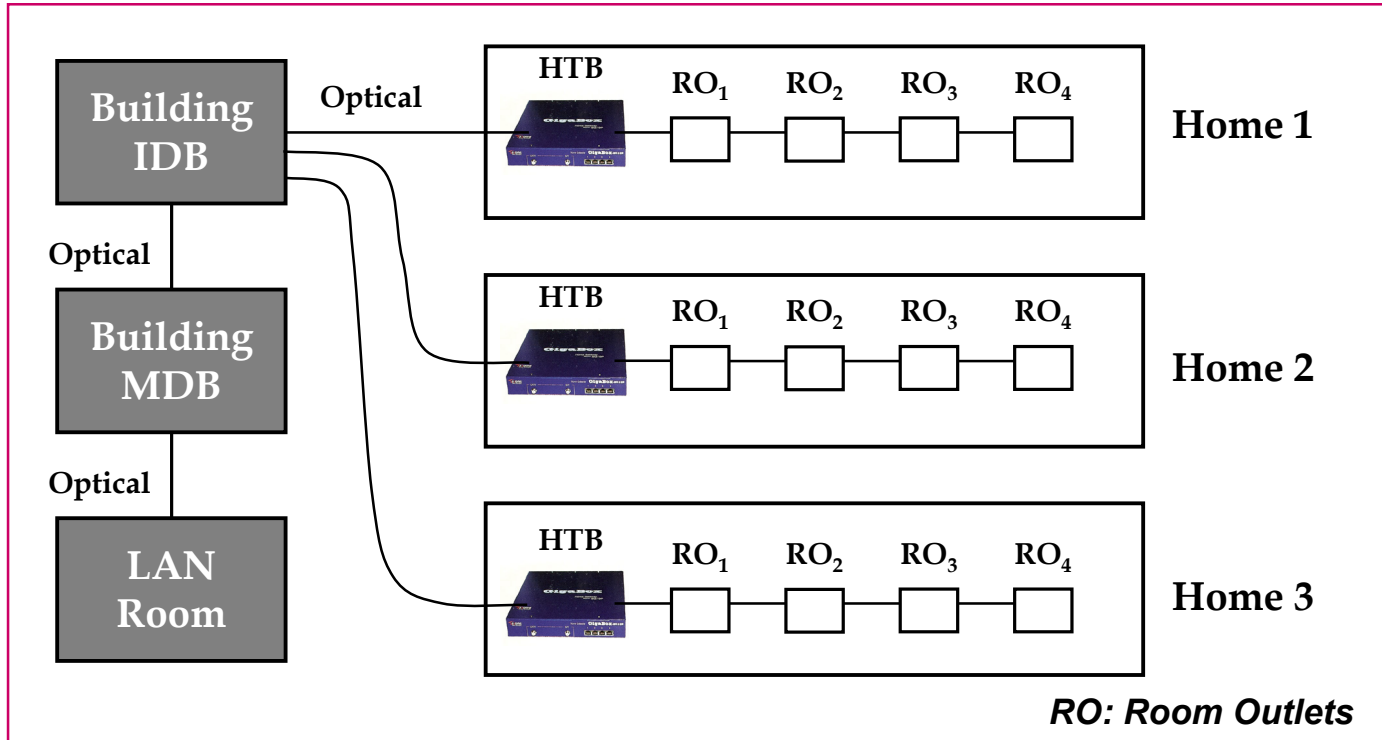

- Cable Installation for Building Intra Network (BIN)

 - Platinum class: > Optical 2 cores/home, 1st class: > Cat. 5e 4 pairs/home

- In Home Wiring: > Cat. 5e 4 pairs/ RO

Implementation of HTTH

- *Labor Standards for Optic Cable (MIC, 2004)*

Cable Installation for GOF / POF

	Gauge/ Unit	Technician	Lineman / A class	Lineman / B class
GOF	8 core/ 10m	0.31	0.13	
POF	8 core/ 10m	0.25	0.10	

Cable Core & Tube Installation for GOF / POF

	Gauge/ Unit	Technician	Lineman / A class	Lineman / B class
Optical core	Assembled Fiber/100m	0.11	0.11	
Optical tube	< 12tube/ 100m	0.71		1.79
	> 12tube/ 100m	0.83		2.10
	Cut & Connection	0.02		0.02

Implementation of HTTH

- *Labor Standards for Optical Cable (MIC, 2004)*

Optic Cable Connection for POF

	Unit	Technician	Lineman /A class
Core connection by mechanical connector	per Core	0.07	-
Field assembling type connector	per Core	0.10	0.10

Broadband Home Network Plan (1st Step)

HGW:

- *Interface between BcN-SAN and In-home Network*
- *Connects all devices of home network to SAN*
- *Path for a certified subscriber to all devices in home network*

STB:

*Tuner, Decoding, Security
and TV output for satellite,
terrestrial, cable TV*
IP STB, Cable STB,
Integrated STB

Middleware:

*UPnP, OSGi, Jini, HAVi
for home appliances
control*

*ATSC / DASE, DVB- MHP,
OCAP for broadcasting*

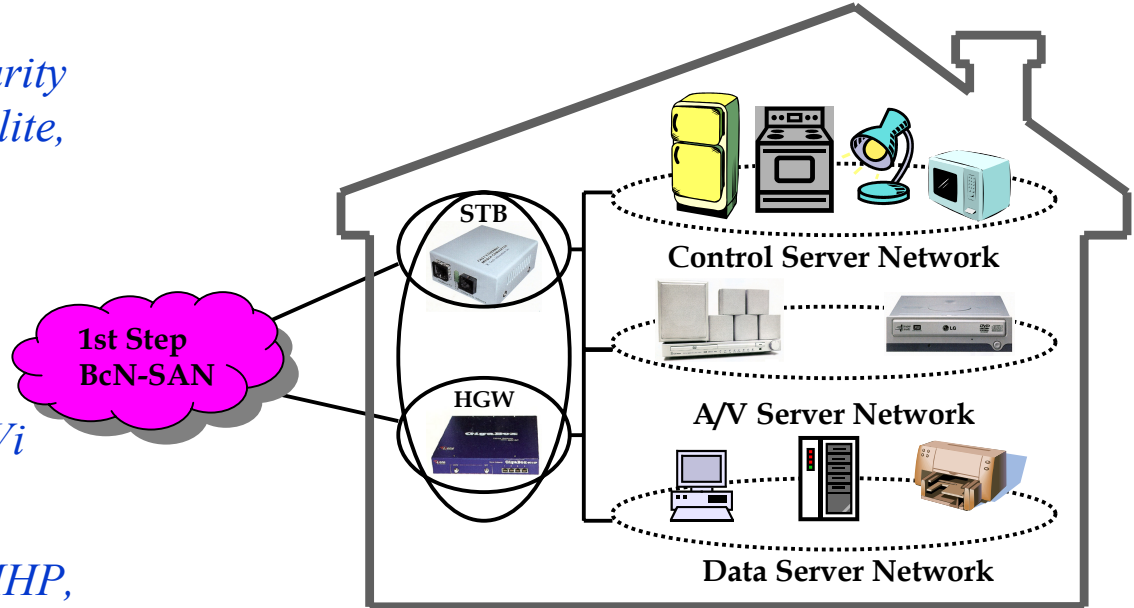

Configuration of home network and terminals in the first step (2004/2005)

In-Home Networking by POF

Broadband Home Network Plan (2nd Step)

HWG:

- *Convergence of telecommunications and broadcasting*
- *Integrated function of HWG and STB in the first step*

Home Back-bone Network (HBN):

*Transmission and Receiving of real time data and non-real time data simultaneously (IEEE 1394)
Unified HN and room based PAN*

2nd Step
BcN-SAN

Bridge:

*Interface for HWG, HBN and PAN
Transmits home devices signals in various standards of 10/100 Ethernet, IEEE1394, WPAN, etc.*

**Wired HBN for new building /
wireless HBN for old building**

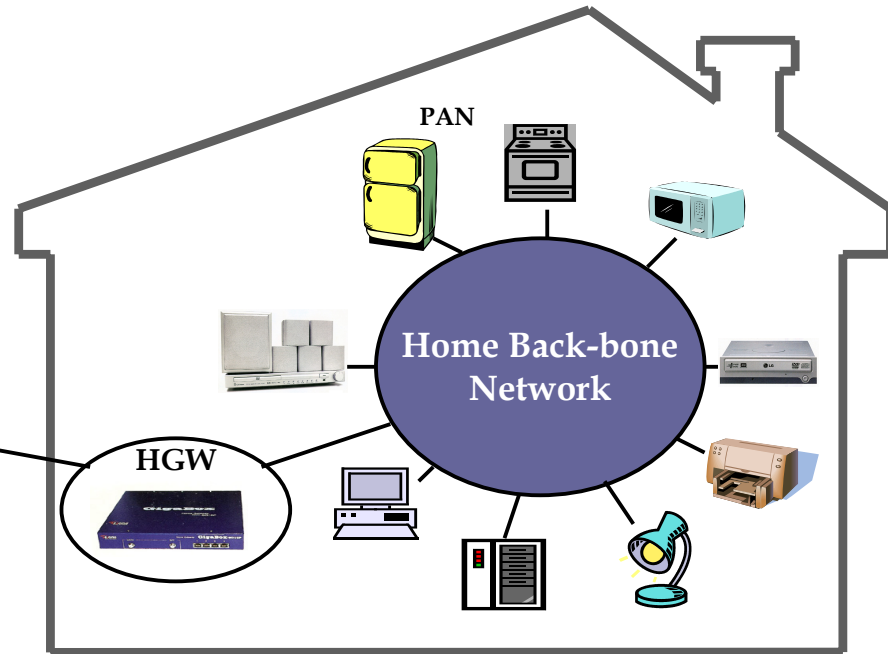

Configuration of home network and terminals in the second step (2006/2007)

POF for Multi-dwelling Unit Buildings

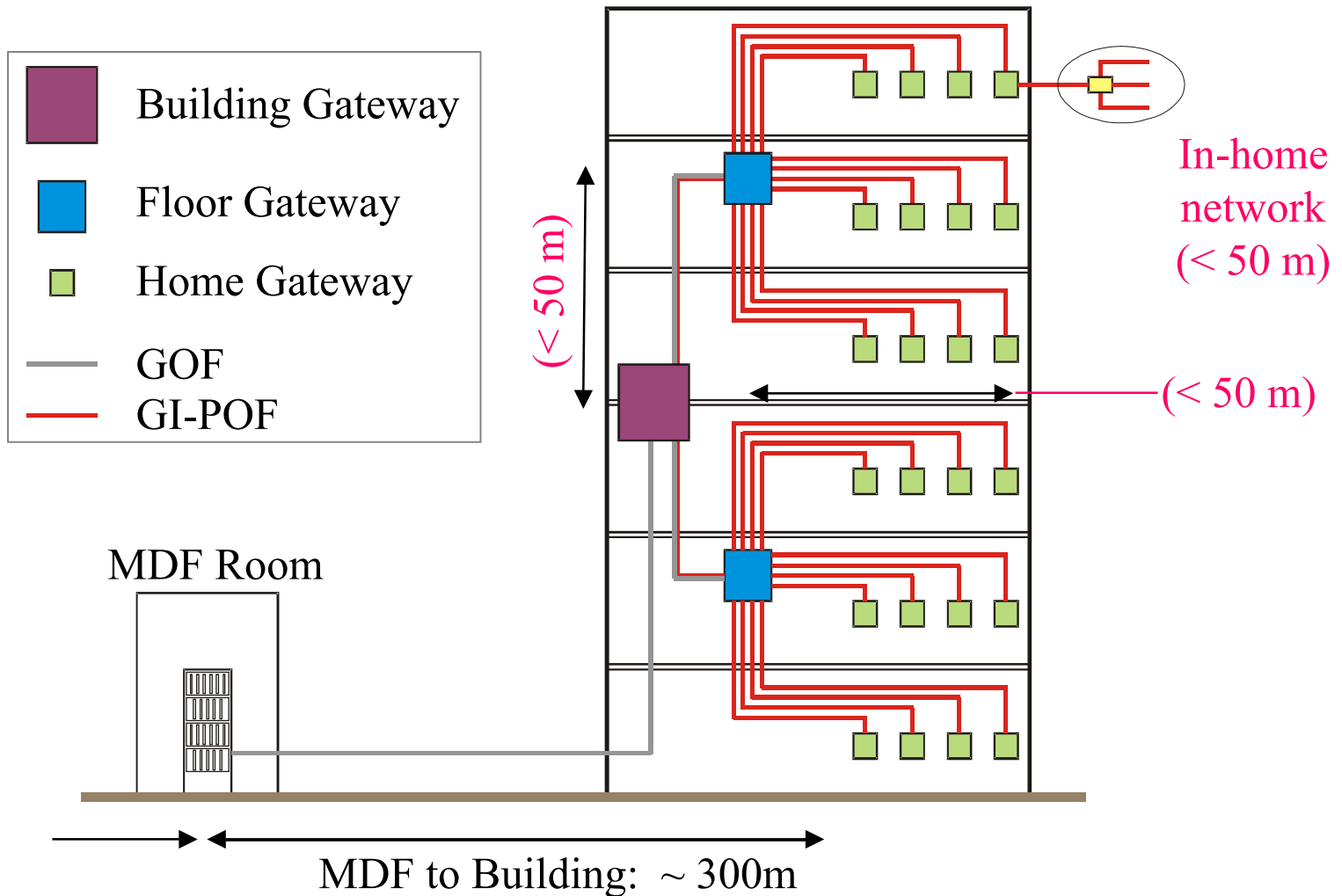

References:

- 1. J.-W. Lee, “BcN, Broadband Home Network & POF”, ICPOF 2005*
 - 2. “POF & Home Network Technology”, Korea POF Communication Forum (Feb.2004)*
 - 3. “POF Technology and Standards”, Korea Information & Communication Contractors Association (Oct. 2004)*
-