

Optical Measurement System for Optical Communications

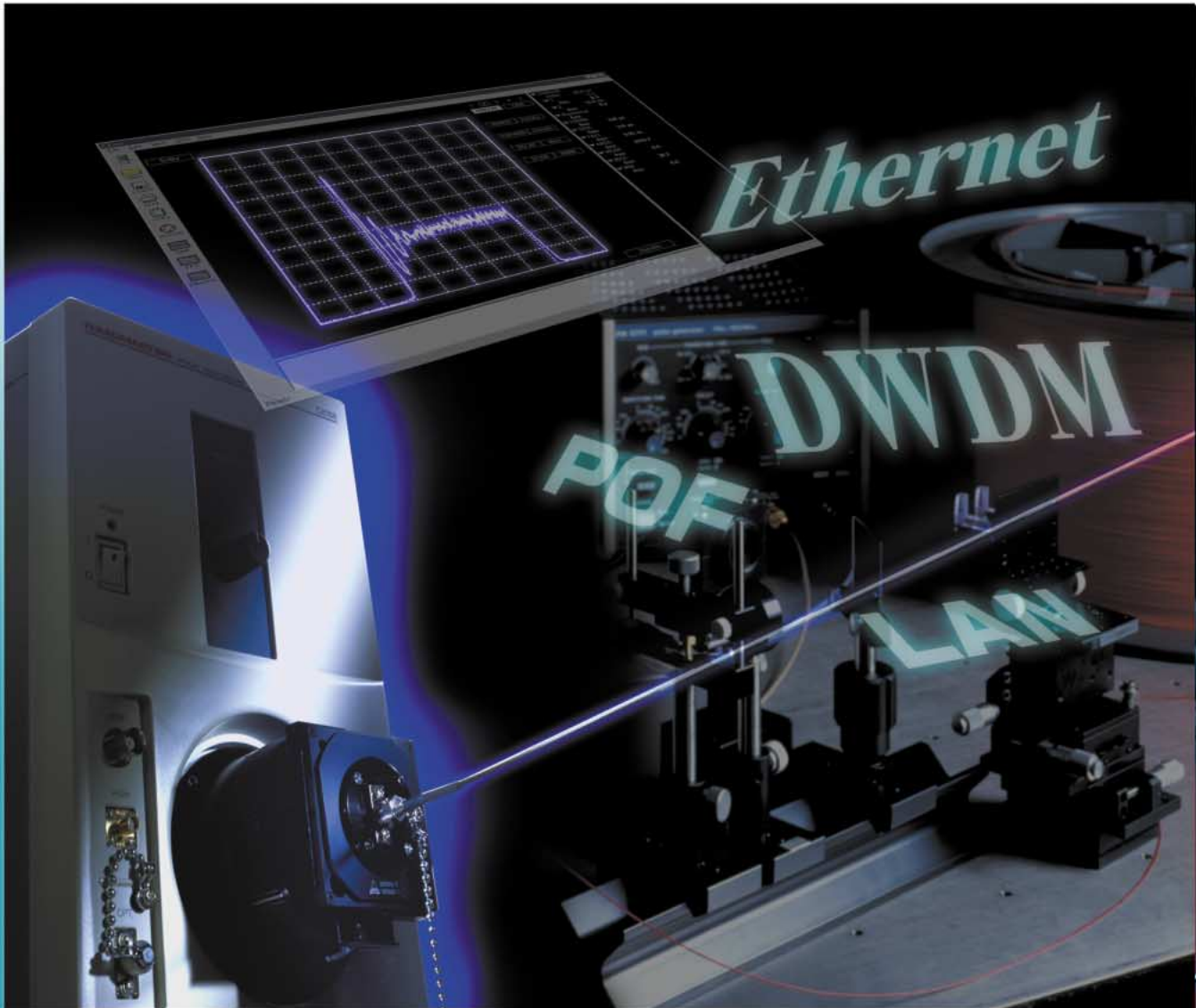

Hamamatsu instruments for optical communication provides four systems. Numerical Aperture (NA) of POF and Near Field Pattern (NFP) of laser diode can be measured with the optical beam measurement system. Transmission characteristics of POF and temporal response characteristics of laser diode can be evaluated with the sampling optical oscilloscope. The real-time optical spectrum analyzer can evaluate the spectrum transmittance of optical fiber coupler. The terabit optical oscilloscope which features 40 Gbps, 16-channel simultaneous measurement, evaluates a device used for DWDM, and DWDM system.

[Optical Communication Region]

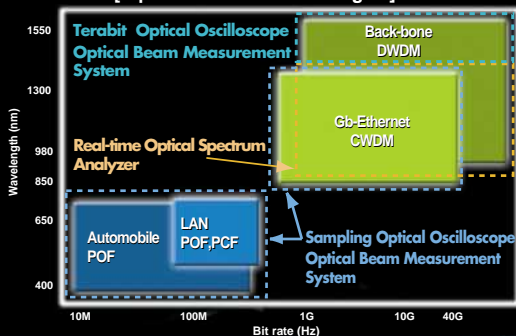

Optical Beam Measurement System

Real-time Optical Spectrum Analyzer

Sampling Optical Oscilloscope

Terabit Optical Oscilloscope

HAMAMATSU

Optical Beam Measurement System

Measure the NA of Fibers

• Overview

The fundamental parameters of fibers include something called the NA. The illustration below shows a system which determines the NA of a fiber instantaneously and in two dimensions, using an FFP optics. The angle distribution of the fiber output beam is converted to a position distribution using the FFP optics, and is then imaged using a camera. The camera output is measured and analyzed using the LEPAS-11 to determine the NA. When measuring a multimode fiber such as an optical plastic fiber, the wide measurement angle range model A3267-12 is used. When measuring a single mode fiber, high resolution model A3267-15 is used.

The C5948-71 CCD camera for laser measurement is used to measure multi-mode fibers, while the C5840-10 near infrared camera, which is quantitative in the infrared range, is used to measure single-mode fibers.

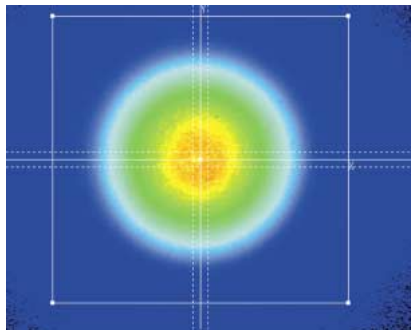

▲ Measurement of POF

• System configuration

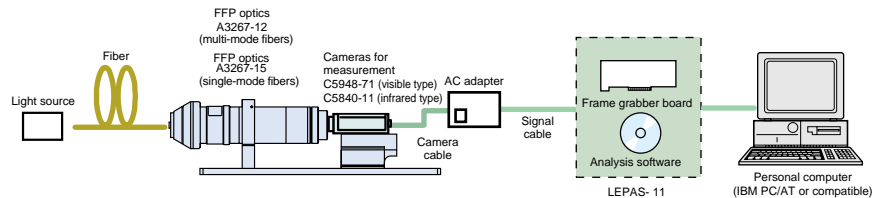

• Main specifications

Optics	A3267-12	A3267-15
Measurement fiber	Multi-mode fiber	Single-mode fiber
Wavelength range	635 nm to 1650 nm	
Allowable fiber core diameter	Within ϕ 1.5 mm	
Measurement NA (angle) range	0.7 ($\pm 45^\circ$)	0.17 ($\pm 10^\circ$)
Resolution	Better than 0.004 (0.2°)	Better than 0.009 (0.05°)
Working distance	approx. 2.8 mm	

Adjust Fiber Collimators

• Overview

Fiber collimators are one of the basic modules used in optical communications. The fiber collimator is a module that combines a fiber and a lens, and has a function that produces parallel beams.

When fiber collimators are manufactured, the positions of the fiber and lens are adjusted so that parallel beams can be obtained, and this generally requires extremely fine adjustments.

The illustration below shows a system in which fiber collimator adjustment is carried out automatically, in a short period of time, using the A3267-10 (or -09, or -13) high-resolution FFP optics, the LEPAS-11, and a power stage. The divergence angle of the output beam is converted to a position distribution by the high-resolution A3267-10 (or -09, or -13) high-resolution FFP optics, and an image is formed by a camera connected later in the sequence.

The camera output is measured and analyzed by the LEPAS-11, and the beam divergence angle is determined instantaneously. The results are fed back to the power stage through GPIB control, and the lens is moved in tiny increments until the optimum position is reached for the minimum beam divergence angle.

The C5948-71 CCD camera for laser measurement is used to measure multi-mode fibers, while the C5840-11 near infrared camera, which is quantitative in the infrared range, is used to measure single-mode fibers.

• System configuration

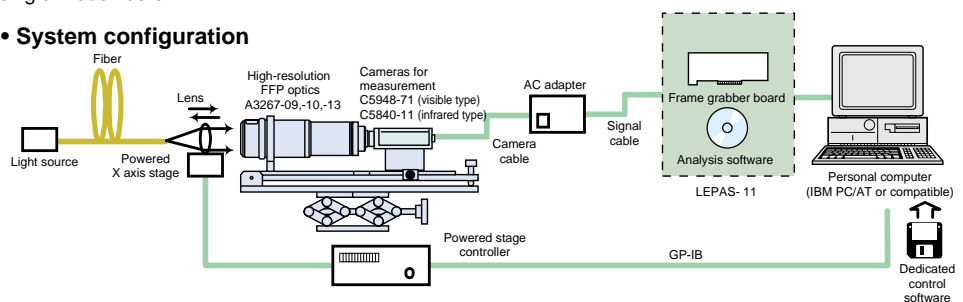

• Main specifications

Optics	A3267-09	A3267-10	A3267-13
Wavelength range ①	480 nm to 680 nm	780 nm to 1650 nm	
Angle alignment range	± 15 mrad		
Angular resolution	Within 0.09 mrad		± 2.42 mrad
Max. receiving light beam	ϕ 10 mm		

① Please consult with Hamamatsu.

Evaluation of Optical Fiber and Laser Diode

Measure the NFP (Near Field Pattern) of Semiconductor Lasers

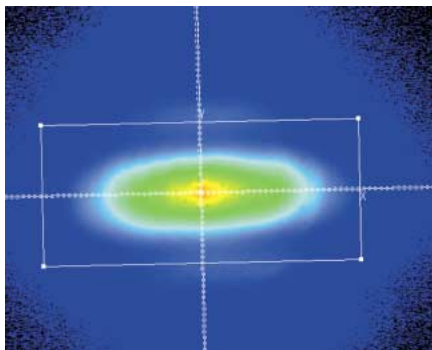

▲ Measurement of near-field image of visible semiconductor laser

• Overview

When the beam from a semiconductor laser is focused through a lens or conducted through a fiber or similar element, it is important to have a clear understanding of the NFP (Near Field Pattern) of the semiconductor laser.

The NFP of a semiconductor laser is extremely small, with a size on the order of $1 \mu\text{m}$, so precise measurement requires an expansion optics with a high rate of magnification.

The illustration below shows a system capable of precise measurement of the semiconductor laser NFP, using an optics with an expansion magnification rate of 500 times (the A4859-01 NFP optics).

The A4859-01 output is connected to a measurement camera, and measurement and analysis are done with the LEPAS-11. Generally, with a magnification rate as high as 500 times, the measurement field of the camera is reduced to an extremely narrow size of around $10 \mu\text{m}$, making position alignment difficult when the measurement is begun. In order to solve this problem, with the A4859-01, a position alignment light path with a magnification of 12.5 times is provided, coaxial to the measurement light path. This makes it easy to detect the beam, and measurement can be carried out rapidly.

Up to the 980 nm wavelength range, the C5948-71 CCD camera for laser measurement can be used, and in longer wavelength ranges, the C5840-11 near infrared camera, which is quantitative in the infrared range up to $1.65 \mu\text{m}$, is used.

• System configuration

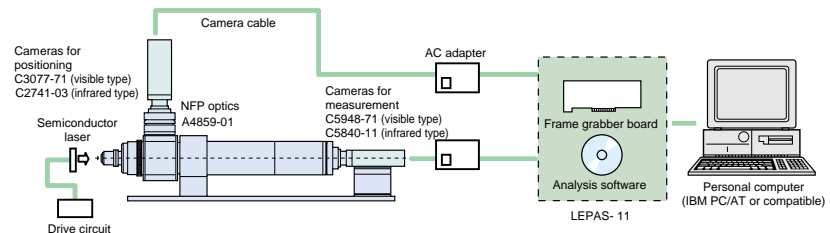

• Main specifications

Wavelength range	635 nm to 1650 nm
Enlargement magnification	Standard: 500 × (optional: 100 ×, 200 ×, 1000 ×)
Position alignment field	Approx. $600 \mu\text{m} \times 500 \mu\text{m}$
Measurement field	Approx. $18 \mu\text{m} \times 13 \mu\text{m}$ ①
Incident NA	0.55 ①
Working distance	Approx. 8.7 mm ①
Reading resolution	Better than $0.03 \mu\text{m}$ ①

① At enlargement magnification of 500 ×



Laser Beam Profiler LEPAS-11

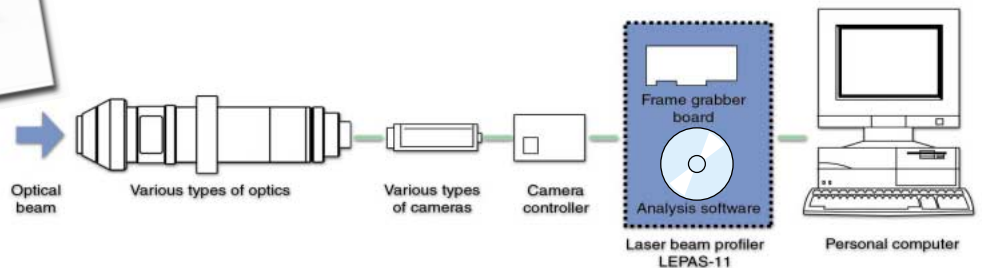

The LEPAS-11 Laser Beam Profiler is the central component at the heart of the optical beam measurement system. Configured of a frame grabber board and a dedicated software package, it is installed in a personal computer (IBM PC/AT or compatible computer) and run from the computer. High-precision, high-speed beam analysis can be carried out easily, simply by connecting the camera output to a frame grabber board.

Real-time Optical Spectrum Analyzer

Evaluation of Optical Fiber Coupler

- System configuration

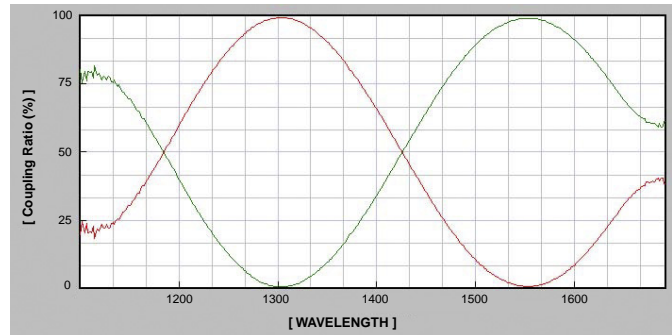
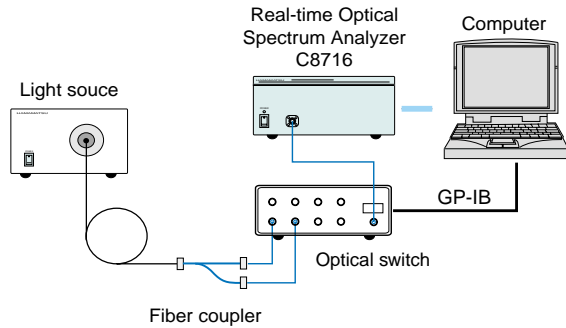

▲ Coupling ratio of optical fiber coupler

Filter Testing

- System configuration

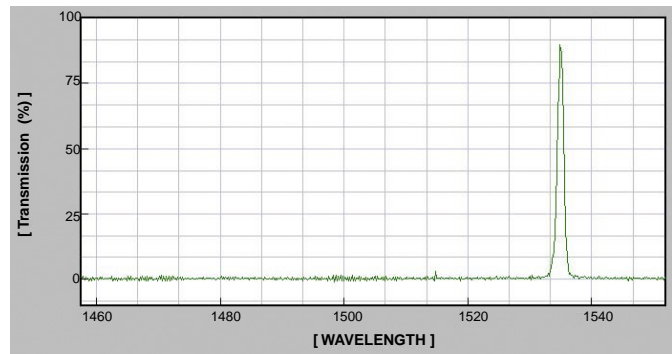
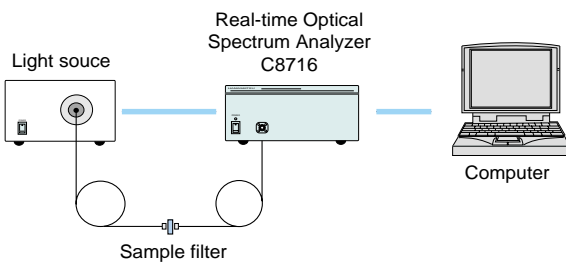

▲ Transmission spectrum of bandpass filter

Thin Film Testing

- System configuration

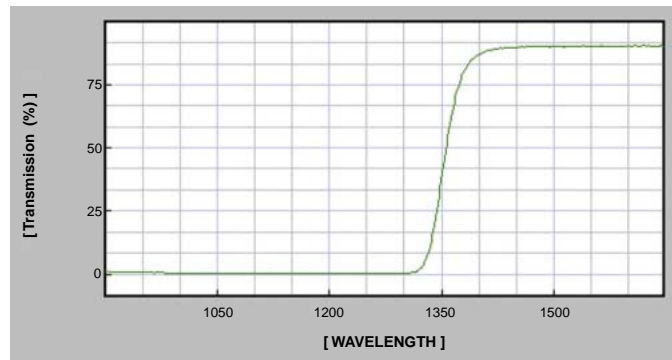
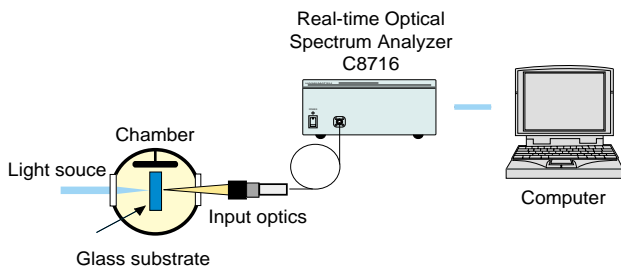

▲ Transmission spectrum of thin film

Evaluation of DWDM Optical Components

Real-time Optical Spectrum Analyzer C8716



The C8716 real-time optical spectrum analyzer is designed to characterize the spectral performance of fiber couplers and filters. A high-performance grating with multi-channel detector is employed allowing instantaneous results - ideal for manufacturing and inspection processes requiring high throughput.

Spectral performance of DWDM components such as filters, couplers, FBG-VAO, and optical amplifiers can be easily characterized by the C8716. Its connectorized input can easily be removed to allow free-space input for bulk type material input.

In addition, its small and lightweight package is well suited for OEM and system integration.

Features

- Excellent wavelength reproducibility
- High sensitivity in the IR region (900 nm to 1600 nm)
- Factory calibrated spectral response and wavelength axis

Applications

- Filter testing
- Evaluation of optical fiber couplers
- Evaluation of Laser Diode emission
- WDM monitor

Measurement Principle

The light (blue) from the optical fiber is launched onto a high performance diffraction grating. The spectrally dispersed light (yellow) is then imaged onto a multi-channel photodetector. This simultaneous capture of the complete spectrum enables real-time analysis of an optical component.

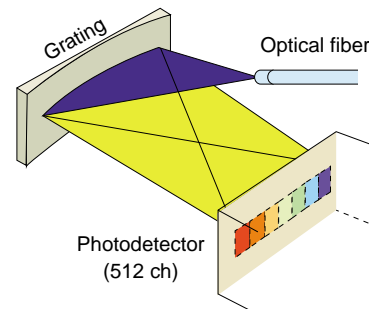

Specifications

Type No.	C8716-01	C8716-02	C8716-03	C8716-04
Photodetector	InGaAs linear image sensor			
No. of photosensitive device channels	512 ch			
A/D resolution	16 bit			
Simultaneous measurement wavelength range	900 to 1650 nm	1400 to 1500 nm	1450 to 1550 nm	1525 to 1625 nm
Wavelength resolution	< 3.0 nm	< 0.6 nm	< 0.6 nm	< 0.6 nm
Minimum measurement time	9 ms			
External trigger input	TTL level / High impedance			
Interface	SCSI			
Line voltage	AC100V to 240V ± 10%			
Operating temperature	+ 10 to + 30°C			
Dimensional outline	262 (W) × 123.5 (H) × 433 (D) mm			

Evaluation of Optical Fiber and Laser Diode

Sampling Optical Oscilloscope C8188



The Sampling Optical Oscilloscope C8188 evaluates response characteristics of semiconductor lasers and ultra-high-speed light sources. It performs all tasks from light detection to signal processing to virtually eliminate waveform distortion.

The wide bandwidth models (C8188-01, -11) have a temporal response characteristic of 20 ps or less and a bandwidth of 20 GHz or more.

The large detection area model (C8188-03) allows easy alignment with optics and it can collect the entire signal of large aperture sources such as plastic optical fibers (POF).

Features

●Virtually no waveform distortion

The Sampling Optical Oscilloscope performs all tasks from light detection to signal processing, eliminating virtually all the waveform distortions that occur in conventional methods involving high-speed optical detectors and oscilloscopes, such as those caused by reflection or ringing.

●Wide bandwidth (20 GHz)

The C8188-01 and C8188-11 have a response characteristic of 20 ps or less and a wide bandwidth of 20 GHz or more.

●Large detection area

The C8188-03 collects the entire signal from large aperture sources such as a 1 mm POF for a highly accurate measurement with a bandwidth of 2 GHz or more.

●Easy operation

No need to consider matching conditions such as impedance, which are necessary in conventional methods.

●Control from PC

The Sampling Optical Oscilloscope is controlled from a PC with a Windows environment to allow easy data storage and connection to a LAN.

Other Application

●Evaluation of characteristics of optical link systems

Specifications

Type No.	C8188-01	C8188-03	C8188-11	C8188-12
Spectral response	350 to 850 nm	350 to 850 nm	400 to 1,300 nm	400 to 1,300 nm
Effective detection area	100 μm \times 3 mm	1 mm \times 3 mm	100 μm \times 3 mm	200 μm \times 3 mm
Bandwidth	20 GHz or more	2 GHz or more	20 GHz or more	5 GHz or more
Optical signal input form	Fixed slit and FC connector	Fixed slit and FC connector	Fixed slit and FC connector	Fixed slit and FC connector
Temporal resolution (rise/fall time)	Better than 17.5ps	Better than 175ps	Better than 17.5ps	Better than 40ps
Time axis	20 ps/div to 1 μs /div	20 ps/div to 1 μs /div	20 ps/div to 1 μs /div	20 ps/div to 1 μs /div
Number of sampling points	1,024	1,024	1,024	1,024
Minimum sampling interval	2.5 ps	2.5 ps	2.5 ps	2.5 ps
Dynamic range	More than 1:1,000	More than 1:100	More than 1:1,000	More than 1:1,000
A/D converter	14bit	14bit	14bit	14bit
Waveform calculation function	Fast Fourier Transform (FFT) operation, rise and fall times, maximum/minimum			
Cursor function	Intensities specified at cursors, intensity ratio, time interval between two specified cursors, area between cursors			
Intensity axis	Linear			
Other functions	Data accumulation, data save and load (text format), print			

Optional

●NA converter : A8684

This unit is recommended for bandwidth measurements of optical fibers.



	FC Input / FC Output	FC Input / SMA Output	FC Input / F05 Output
Input NA 0.2 / Output NA 0.2	A8684-01	A8684-11	A8684-21
Input NA 0.2 / Output NA 0.4	A8684-02	A8684-12	A8684-22
Input NA 0.2 / Output NA 0.65	A8684-03	A8684-13	A8684-33

●Optical fiber for all mode excitation : A8685

Use the A8685 to connect the picosecond light pulser and the NA converter.

A8685: Core size: 20 μm , Length: 3 m, FC/FC connector

Spectral Response

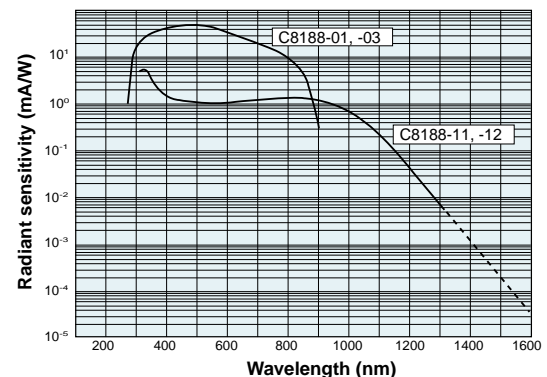

Terabit Optical Oscilloscope

Measurement Example of 6.4Gb Pattern

• System configuration

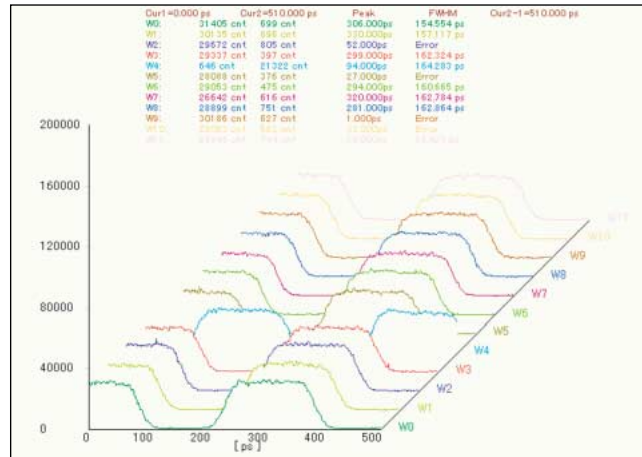
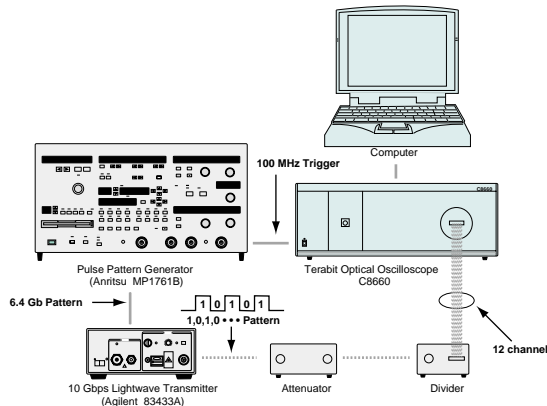

Terabi Optical Oscilloscope C8660



Due to its bandwidth of 70 GHz per channel, this device can measure high-speed optical-communication signals (at 10 Gbps or 40 Gbps) with high precision.

Moreover, since simultaneous measurement of up to 16 channels is possible, multi-channel evaluation of characteristics of DWDM devices can be performed rapidly.

Features

- Wide bandwidth measurement of 70 GHz or more
- Simultaneous measurement of 16 ch (optional)
- Virtually no distortion of waveform

Applications

- Evaluation of optical device for DWDM
- Evaluation of DWDM system

Specifications

Bandwidth	> 70GHz × 16 ch (max.)
Temporal resolution	< 5ps
Spectral response	300 to 1650 nm
Optical input connector	MPO connector: 12 ch (standard), 16ch (optional)
Simultaneous optical input	12 ch (standard), 16ch (optional)
Trig. input frequency	99.5328MHz or 100MHz
Trig. input level	- 3 dBm to +5 dBm / SMA connector
Delay range	> ±5ns
Measurement time range	100ps / 200ps / 500ps / 1ns
Interfaces	USB: Control IEEE1394: Data transfer
Data analysis	Rise time / Fall time / FWHM / Time Difference
Accessories	12 ch MPO-12ch SC connector



★ Product and software package names noted in this documentation are trademarks or registered trademarks of their respective manufacturers.

- Subject to local technical requirements and regulations, availability of products included in this promotional material may vary. Please consult with our sales office
 - Information furnished by HAMAMATSU is believed to be reliable. However, no responsibility is assumed for possible inaccuracies or omissions.
- Specifications and external appearance are subject to change without notice.

© 2002 Hamamatsu Photonics K.K.

HAMAMATSU

Homepage Address <http://www.hamamatsu.com>

HAMAMATSU PHOTONICS K.K., Systems Division

812 Joko-cho, Hamamatsu City, 431-3196, Japan, Telephone: (81)53-431-0124, Fax: (81)53-435-1574, E-mail: export@sys.hpk.co.jp

U.S.A. and Canada: Hamamatsu Photonic Systems: 360 Foothill Road, Bridgewater, N.J. 08807-0910, U.S.A., Telephone: (1)908-231-1116, Fax: (1)908-231-0852, E-mail: usa@hamamatsu.com

Germany: Hamamatsu Photonics Deutschland GmbH: Arzbergerstr. 10, D-82211 Herrsching am Ammersee, Germany, Telephone: (49)8152-375-0, Fax: (49)8152-2658, E-mail: info@hamamatsu.de

France: Hamamatsu Photonics France S.A.R.L.: 8, Rue du Saule Trapu, Parc du Moulin de Massy, 91882 Massy Cedex, France, Telephone: (33)1 69 53 71 00, Fax: (33)1 69 53 71 10, E-mail: infos@hamamatsu.fr

United Kingdom: Hamamatsu Photonics UK Limited: 2 Howard Court, 10Tewin Road, Welwyn Garden City, Hertfordshire, AL7 1BW, U.K., Telephone: (44) 1707-294888, Fax: (44) 1707-325777, E-mail: info@hamamatsu.co.uk

North Europe: Hamamatsu Photonics Norden AB: Smidesvägen 12, SE-171-41 Solna, Sweden, Telephone: (46)8-509-031-00, Fax: (46)8-509-031-01, E-mail: info@hamamatsu.se

Italy: Hamamatsu Photonics Italia S.R.L.: Strada della Moia, 1/E 20020 Arese (Milano), Italy, Telephone: (39)02-935 81 733, Fax: (39)02-935 81 741, E-mail: info@hamamatsu.it

Cat. No. SLS11012E01

MAY/2002 HPK

Created in Japan (PDF)